

Linear Hidden Lighting / Office Extension

Cat.No. 28.B.009

Linear hidden lighting

Length: 225 cm.

Depth: 17.8 cm.

Height: 17.2 cm.

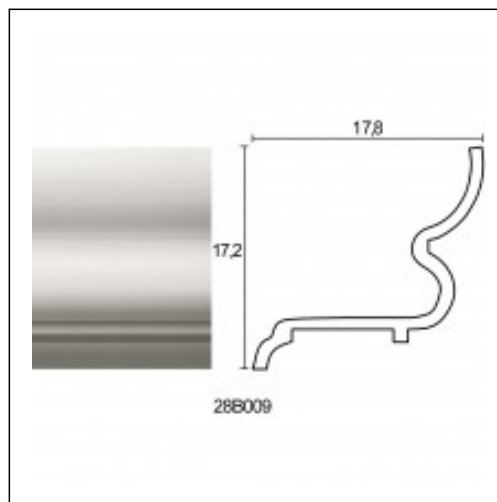

RELATIVE PRODUCT PHOTOS



RELATIVE WORKS



Residence in Pallini
Residences
Jul '00