

## Glyphic Cornices / Angel - Matting Composition

Cat.No. 29.L.010

Glyphic Cornice

**Length:** 80 cm.

**Depth:** 26 cm.

**Height:** 19 cm.

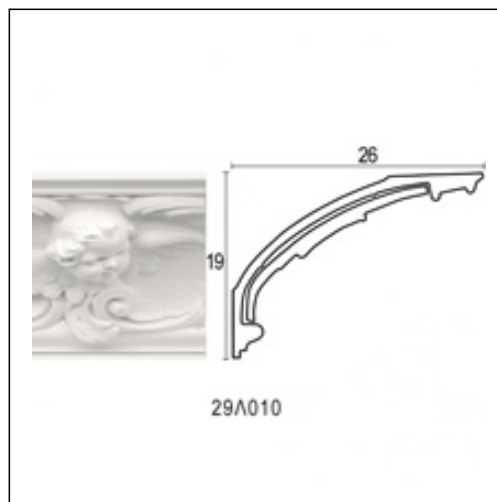

### RELATIVE PRODUCT PHOTOS



### RELATIVE PRODUCTS



Ring 150cm  
Domes  
Cat.No.