

Capitals / American 3

Cat.No. 36.U.008

Width: 24 cm.
Length: 24 cm.
Height: 14.5 cm.
F1: 15.2 cm.

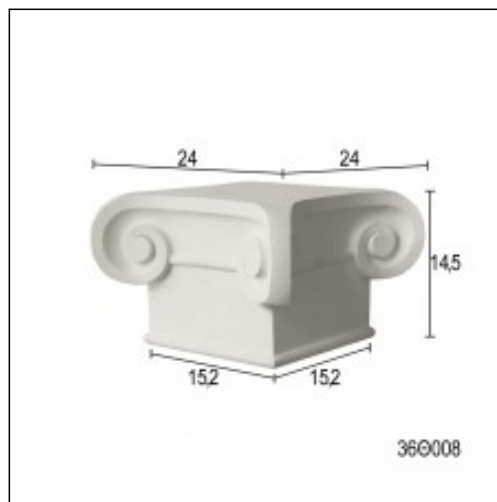

RELATIVE PRODUCTS



American
Columns
Cat.No.